

V-ZPL06 / V-ZPL12 / V-ZPL1050 / V-ZPL-214 / V-ZPL-318

High Tech Zoom Pinhole Lenses

- Available in 4-20mm Zoom or 10-50mm Zoom
- Removable push-on cap also acts as mounting support
- Manual or Motorized Control
- Used for Industrial and Security Applications
- High Quality Glass Elements
- For 1/3" CCD with CS-Mount
- 7-12VDC operation
- 6" and 12" Long



V-ZPL-214 / V-ZPL-214MZ

V-ZPL-318 / V-ZPL-318MZ

These lenses are ideal for those tough situations where the camera must be hidden and provide any angle of view between 4-20mm or 10-50mm. Although designed for 1/3" electronic iris cameras, these lenses are also useful on 1/2" cameras where they can provide up to a 120 degree horizontal field of view at 4mm. The tip of the pinhole is built in to a removable push-on cap that also acts as a mounting support and protects the main optical system from damage. The motorized MZ series requires 7-12VDC to power the zoom motor. Recommended voltage is 9VDC.

* $f\text{-stop} = \text{focal length} / 1.6$

Specifications - High Tech Zoom Pinhole Lenses				
Part No	Range	Control	F-Stop	O.D. x L
V-ZPL-06	4-20mm	Manual	f2.5@4mm*	0.787" x 4"
V-ZPL-06MZ	4-20mm	Motorized	f2.5@4mm*	0.787" x 4"
V-ZPL-12	4-20mm	Manual	f2.5@4mm*	0.787" x 13"
V-ZPL-12MZ	4-20mm	Motorized	f2.5@4mm*	0.787" x 13"
V-ZPL-1050	10-50mm	Manual	f2.5@10mm*	0.787" x 4.50"
V-ZPL-1050MZ	10-50mm	Motorized	f2.5@10mm*	0.787" x 4.50"
V-ZPL-214	2.8-14mm	Manual	f2.5@4mm*	0.79" x 3.56"
V-ZPL-214MZ	2.8-14mm	Motorized	f2.5@4mm*	0.79" x 3.56"
V-ZPL-318	3.6-18mm	Manual	f2.5@4mm*	0.79" x 3.56"
V-ZPL-318MZ	3.6-18mm	Motorized	f2.5@4mm*	0.79" x 3.56"

V-ZPL06-MZ/
V-ZPL06



V-ZPL1050-MZ/
V-ZPL1050



V-ZPL12-MZ / V-ZPL12



V-ZPL-05-01
Mini zoom pinhole lens
with removable pinhole cap



V-ZPL-05-12
Mini zoom pinhole lens
with fixed pinhole cap



V-ZPL-05-02
Mini zoom pinhole lens
with fixed pinhole cap



V-ZPL-05-01 / V-ZPL-05-02 / V-ZPL-05-12
Mini Zoom Pinhole Lenses

Specifications - Mini Zoom Pinhole Lenses					
Part No.	Focal Length	Image Sensor Format	Mount	Diagonal FOV	Dimensions
V-ZPL-05-01	2.5mm - 10.0mm	1/4"	CS	84° ~ 25°	19 x 52mm
V-ZPL-05-02	2.5mm - 10.0mm	1/4"	CS	84° ~ 25°	19 x 52mm
V-ZPL-05-12	2.5mm - 10.0mm	1/4"	M12	84° ~ 25°	19 x 52mm

High Resolution, Low Light Pinhole Lenses

Specifications - High Resolution, Low Light Pinhole Lenses					
Part No	V-PL28CS	V-PL35C	V-PL35CS	V-PL45CS	V-PL60CS
Focal Length	2.8mm	3.5mm	3.5mm	4.5mm	6.0mm
Aperture	f1.0	f1.4	f1.4	f1.8	f1.8
Angular *(H)	98°	85°	85°	71°	56°
Field *(V)	81°	69°	69°	56°	44°
of View *(D)	110°	88°	88°	83°	67°
Dimensions	30 x 100mm	28 x 104mm	28 x 109mm	20 x 97mm	18 x 79mm
Mount	CS	C	CS	CS	CS
Pinhole Size	3mm	3mm	3mm	2.5mm	3mm
Cone Depth	13mm	13mm	13mm	9.5mm	11mm

*** V-PL28CS - World's Fastest Pinhole Lens!**

These manual iris pinhole lenses are designed for 1/3" format CCD cameras. State of the art optical design for color or B&W cameras in low light conditions. New push-on cap with built-in mounting clamp for convenient installation. The push-on cap protects optics from damage.



V-ZPT2 (*Lens and Camera not included)

V-ZPT4 (*Lens and Camera not included)

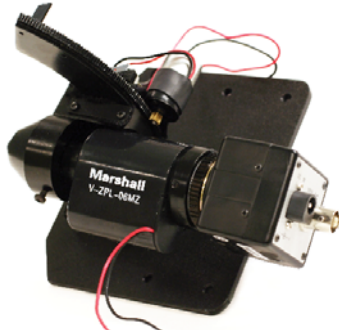

- 2-way - V-ZPT2 (Pan only)
- 4-way - V-ZPT4 (Pan and Tilt)
- Quiet Sounding Motors, 9-12VDC operation
- 120 Degree Axis



Mounting in the Wall

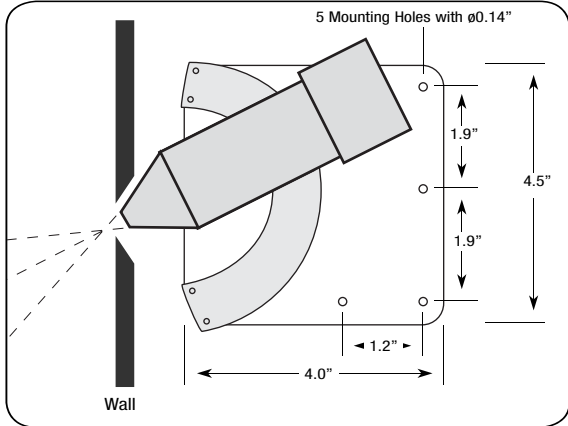

These unique motorized pan and tilt mechanisms are specially designed by Marshall Electronics for our line of motorized zoom pinhole lenses. They pan either back and forth, up and down (V-ZPT2), or both (V-ZPT4) at approximately 120 degree angle each axis. Recommended lenses are the motorized pinhole lenses (V-ZPL06MZ and V-ZPL1050MZ). With these lenses plus this unique mechanism, you can pan and tilt your camera and zoom in and out to a particular subject at 4-20mm (V-ZPL06MZ) or 10-50mm (V-ZPL1050MZ) range. Operates with 9-12VDC of power @ 500mA (not included) and are capable of lifting up to a 100g camera. Ideal cameras to use are C/CS-Mount B/W, color board cameras, or enclosed cameras such as the V-1055-BNC.

The V-ZPT2 has 2-way movement, while the V-ZPT4 has 4-way pan and tilt. Each comes with the necessary motors with leads ready to be wired to a control source (control source not included or available). Some of its unique features are very low motor noise, compact size, and easy installation. Power supply not included.

Long Focus Pinhole Lenses



V-PL300C

V-PL200C

V-PL150C

These Long Focus lenses are designed for covert operations where it is necessary to have pinhole features while keeping the camera well away from the viewing tip. These can be used when looking through bushes or walls up to 14.81" thick.

- High Tech Optical Design
- 150, 200, and 300mm
- High Quality Glass Optics

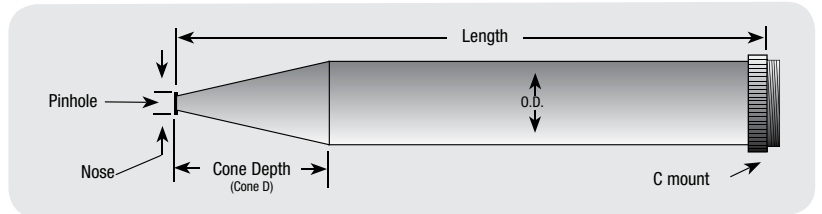

Specifications - Long Focus Pinhole Lenses									
Part No	Focal Length	f-stop	Format	Mount	Field of View (HxVxD)	Nose	Pinhole ϕ	Cone D	O.D x L
V-PL150C	150mm	f20-C	2/3" CCD	C	3.25° x 2.45° x 4.10°	0.4" ϕ	0.1"	1.57"	0.98" x 8.0"
V-PL200C	200mm	f20-C	2/3" CCD	C	2.50° x 1.78° x 3.20°	0.4" ϕ	0.1"	1.95"	0.98" x 10.81"
V-PL300C	300mm	f30-C	2/3" CCD	C	1.68° x 1.25° x 2.30°	0.52" ϕ	0.17"	2.50"	0.98" x 14.81"

High Tech Pinhole Laparoscopic Lenses



V-LPL8 on a V-1056 B&W CCD Camera

- High Tech Optical Design
- 0.31" O.D.
- High Quality Glass Elements

Specifications - High Tech Pinhole Laparoscopic Lenses						
Part No	Length	Focal	F-stop	Horizontal Angle of View	Format	Mount
V-LPL5	9.4"	4.4mm	f5.0	58°	1/3" CCD	CS
V-LPL8	4.65"	4.4mm	f5.0	58°	1/3" CCD	CS
V-LPL10-CS-12	10.5"	6.5mm	f5.0	41°	1/3" CCD	CS or 12mm
V-LPL13	10.5"	6.5mm	f5.0	41°	1/3" CCD	Eye View

Measuring only 0.31" in diameter, the V-LPL can be hidden behind walls or ceilings for covert applications. Using the most advanced optical design, the tube of the pinhole lens contains several lenses to provide clear images. The V-LPL8 and V-LPL5 can be used on 1/3" CCD B&W cameras where they provide 81° angle of view at 4.4mm focal length.

Wide Angle and Long Focal Length Pinhole Lenses

V-PL26-CS / V-PL26-CS-R / V-PL27-CS-R / V-PL27-CS-120

These lenses are the latest generation pinhole CCTV lens technology. They provide high resolution and high fidelity images with very little distortion. They can see an entire room through a hole less than 0.15 inch. These lenses are designed to work with 1/3", 1/4", and 1/5" format CCD cameras. 12mm or CS-Mount to accommodate miniature and standard CCTV applications. Focal lengths range from 2.5mm to 70mm for any covert surveillance application.

**Angle of view reflects 1/3" chip. For 1/4" chip, multiply values by 0.75*

Specifications - Wide Angle & Long Focal Length Pinhole Lenses							
Part No.	Focal Length	Aperture	Angular *(H)	Field *(V)	of View *(D)	Dimensions	Mount
V-PL26-CS	2.6mm	f 2.8	85°	69°	98°	15 x 100mm	CS
V-PL26CS-R	2.6mm	f 2.8	85°	69°	98°	58 x 77.3mm	CS

Specifications - Wide Angle & Long Focal Length Pinhole Lenses			
V-PL27-CS-R	2.7mm CS 1/4"	V-PL27-CS-120	2.7mm CS 1/4"
Focal Length	2.7mm	Focal Length	2.7m
Angular *(H)	67°	Angular *(H)	67°
Field *(V)	54°	Field *(V)	54°
of View *(D)	79°	of View *(D)	79°
Dimensions	43.3mm x 36.8mm	Dimensions	33.8mm x 47.2mm
Mount	CS	Mount	CS or 12mm
		Pinhole Size	.04"
		Cone Depth	.25"



V-PL26-CS-R
Amazing technology
right angle pinhole lens

V-PL26-CS
Long barrel
2.6mm pinhole lens



V-PL27-CS-R
Right angle
2.7mm pinhole lens

V-PL27-CS-120
120° angle
2.7mm pinhole lens



2.5mm - V-PL25CS-12



6.0mm - V-PL60CS-12



10mm - V-PL100CS-12



15mm - V-PL150CS-12



30mm - V-PL300CS-12



45mm - V-PL450CS-22



70mm - V-PL700CS-22

**Angle of view reflects 1/3" chip. For 1/4" chip, multiply values by 0.75*

Specifications - Wide Angle & Long Focal Length Pinhole Lenses							
Part No.	V-PL25CS-12	V-PL60CS-12	V-PL100CS-12	V-PL150CS-12	V-PL300CS-12	V-PL450CS-22	V-PL700CS-22
Focal Length	2.5mm	6.0mm	10mm	15mm	30mm	45mm	70mm
Aperture	f 2.8	f 4.0	f 4.0	f 5.6	f 11	f 8.0	f 12
Angular *(H)	88°	44°	27°	18°	9°	6°	4°
Field *(V)	71°	33°	20°	14°	7°	5°	3°
of View *(D)	100°	53°	33°	22°	11°	7.6°	5°
Dimensions	13 x 46.5mm	12 x 18.5mm	12 x 21.5mm	12 x 25.5mm	12 x 38.5mm	22 x 56mm	22 x 78.5mm
Mount	CS or 12mm	CS or 12mm	CS or 12mm	CS or 12mm	CS or 12mm	CS only	CS only

New Product

NEW 323mm OVERALL LENGTH MODELS HIGH TEMPERATURE UP TO 1000° HARSH ENVIRONMENT ZOOM PINHOLE LENSES

These amazing lenses feature stainless steel housing for extreme durability in harsh environments. High temperature operation, up to 10 minutes at 1000° C with sapphire and quartz front elements. Will withstand impact from scatter sand at high temps. Extreme durability from gravel impact. These lenses are used in extreme and harsh industrial or hostile environments. The New 323mm overall length V-ZPL-HITEMP models are designed for industrial process high temperature environments where observation windows are structurally recessed.

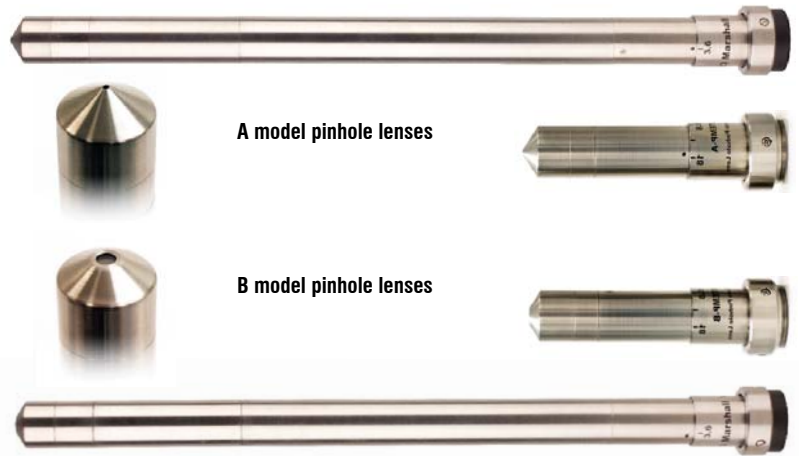

Specifications - Zoom Pinhole Lenses						
Part No	Focal Length	Aperature	FOV	Image Sensor Format	Mount	Pinhole Diameter
V-ZPL-HITEMP-A	3.6mm - 18.0mm	f1.8 - F9.0	80° ~ 19°	1/3"	CS	1.2mm
V-ZPL-HITEMP-A-323	3.6mm - 18.0mm	f1.8 - F9.1	80° ~ 19°	1/3"	CS	1.2mm
V-ZPL-HITEMP-B	3.6mm - 18.0mm	f1.8 - F9.1	80° ~ 19°	1/3"	CS	3.8mm
V-ZPL-HITEMP-B-323	3.6mm - 18.0mm	f1.8 - F9.1	80° ~ 19°	1/3"	CS	3.8mm

Construction	Housing	Optical Elements	Max Op Temp
A model	stainless steel	quartz front elements	Up to 10 min at 1000° C
B model	stainless steel	sapphire front first element, quartz second element	Up to 10 min at 1000° C

V-ZCAM4

Changes Camcorders to Covert Operation

- Installs directly to front of camcorder zoom lens with quick mount tip sleeve
- 70° angle of view (allows you to observe the motion of a nearby person)
- Expands the view angle of camcorders
- High resolution image
- High quality optics
- Compatible with most camcorders using four included lens adapter rings

The V-ZCAM4 pinhole lens adapts to most camcorders with 37mm, 30.5mm, 30mm, or 27mm filter thread for covert applications. It can operate inside a bag or suitcase or even behind a curtain or wall. The pinhole lens has specially designed optics that inverts the image allowing controls to be accessed through a bag or suitcase. Four lens adapter rings included for most camcorders.



Included in Package



V-ZCAM4 Lens Quick Mount Tip Sleeve 3 Viewing Tips

4 Adapter Rings Included



Sony Analog 37mm x 0.75 Sony Digital 30mm x 0.75 Panasonic 30.5mm x 0.5 JVC 27mm x 0.5

V-VML0224A High Zoom Video Microscope Lens



The V-VML0224A High Zoom Video Microscope Lens offers a high zoom ratio 12 times the maximum field line to 30mm. It is compatible with CS-Mount video cameras for image monitoring or direct visual observation with the included eyepiece. The field of view and high zoom ratio provides the latest advanced video microscope lens technology. *monitor not included.

Specifications - High Zoom Video Microscope Lens	
Camera Format	CS-Mount 1/3" image sensor
Magnification Range	0.2 - 2.4 continuously adjustable
Line-field	30 - 2.5mm
Working Distance	100mm
Aperture	NA = 0.015-0.1
Dimension	46mm ø x 267mm

Miniature Glass Lenses For Board Cameras



4300 Series Miniature Fixed Lenses

The **4300 series lenses** have M12 x .5 thread and are compatible with various bullet, board, and case cameras. The V-LH04 lens holder can be used for OEM designs. Custom designed metal or plastic lens holders are available to meet any requirement. For more information, please call us or visit our web site.

Specifications - 4300 Series Miniature Fixed Lenses for Board Cameras

Part No.	Focal Length	Relative Aperture	Sensing Area	Back Focal Length	Angular Field of View								
					1/3" CCD			1/4" CCD			1/5" CCD		
					(H)	(V)	(D)	(H)	(V)	(D)	(H)	(V)	(D)
V-4301.68-2.5FT	1.68mm	2.5	1/4"	3.48	-	-	-	132.9°	101.1°	170°	108.9°	91.1°	147°
V-4301.9-2.0FT	1.9mm	2	1/4"	4.1	-	-	-	107°	78°	142°	83°	68°	119°
V-4301	2.1mm	2	1/3"	5.6	92°	81°	112°	87°	65°	109°	70°	59°	95°
V-4302	2.9mm	2	1/3"	5.88	74°	63°	101°	68°	50°	88°	54°	45°	75°
V-4302-2	2.9mm	2	1/3"	5.85	74°	63°	101°	68°	50°	88°	54°	45°	75°
V-4303-2.0	3.0mm	2	1/3"	5.75	72°	61°	97°	52°	43°	73°	45°	36°	63°
V-4303-2.0FT	3.0mm	2	1/3"	5.75	72°	61°	97°	52°	43°	73°	45°	36°	63°
V-4303.5-1.9	3.5mm	1.9	1/3"	4.26	65°	55°	89°	59°	44°	78°	47°	39°	66°
V-4303.6-1	3.6mm	2	1/3"	4.55	63°	53°	87°	57°	41°	75°	44°	36°	63°
V-4303.6-1-2FT	3.6mm	2	1/3"	4.55	63°	53°	87°	57°	41°	75°	44°	36°	63°
V-4303.6-1.8	3.6mm	1.8	1/3"	4.7	63°	53°	87°	57°	41°	75°	44°	36°	63°
V-4303.6-4	3.6mm	2	1/3"	5.6	63°	53°	87°	57°	41°	75°	44°	36°	63°
V-4304-1	4.0mm	2	1/3"	6.7	58°	48°	80°	52°	37°	68°	40°	33°	57°
V-4304.3-2.0	4.3mm	2	1/3"	6.4	56°	44°	75°	49°	35°	64°	38°	31°	54°
V-4304.9-FT	4.9mm	2	1/4"	6.2	-	-	-	46°	35°	58°	37°	31°	50°
V-4305.7	5.7mm	2	1/3"	7.7	42°	35°	60°	38°	27°	50°	29°	23°	42°
V-4305.7-1.3-A	5.7mm	1.4	1/3"	5.2	-	-	-	46°	35°	58°	37°	31°	50°
V-4306.5-1.5	6.5mm	1.5	1/3"	6.5	37°	31°	52°	33°	23°	44°	25°	21°	37°
V-4306.5-1.8	6.5mm	1.8	1/3"	6.5	37°	31°	52°	33°	23°	44°	25°	21°	37°
V-4306.5-2.0	6.5mm	2	1/3"	6.5	37°	31°	52°	33°	23°	44°	25°	21°	37°
V-4308	8.0mm	2	1/3"	9.53	31°	25°	44°	27°	19°	37°	21°	17°	30°
V-4308-2	8.0mm	2.5	1/3"	6.33	31°	25°	44°	27°	19°	37°	21°	17°	30°
V-4308-2FT	8.0mm	2.5	1/3"	6.33	31°	25°	44°	27°	19°	37°	21°	17°	30°
V-4312	12.0mm	2	1/3"	9.4	20°	17°	30°	18°	13°	25°	14°	11°	20°
V-4312-FT	12.0mm	2	1/3"	10	20°	17°	30°	18°	13°	25°	14°	11°	20°
V-4316-2.0	16.0mm	2	1/3", 1/2"	12	17°	13°	21°	13°	10°	16°	10°	7°	12°
V-4316-2.5	16.0mm	2.5	1/3", 1/2"	12	17°	13°	21°	13°	10°	16°	10°	7°	12°
V-4325	25.0mm	2.5	1/3", 1/4", 1/2"	8	10°	8°	14°	7°	5°	10°	6°	4°	8°
V-4335-2.0	35.0mm	2	1/3", 2/3", 1/2"	18.9	7°	6°	11°	5°	4°	7°	3°	3°	6°
V-4350-2.5	50.0mm	2.5	1/3", 1/2"	33.78	6°	4°	7°	4°	3°	5°	3°	2°	4°



4100 Series Miniature Fixed Lenses

The **4100 series lenses** have M9 x .05 thread and are compatible with various bullet, board, and case cameras. Custom designed metal or plastic lens holders are available to meet any requirement. For more information, please call us.

Specifications - 4100 Series Miniature Fixed Lenses for Board Cameras

Part No.	Focal Length	Relative Aperture	Sensing Area	Back Focal Length	Angular Field of View								
					1/3" CCD			1/4" CCD			1/5" CCD		
					(H)	(V)	(D)	(H)	(V)	(D)	(H)	(V)	(D)
V-4102.5-2.0	2.5mm	2.0	1/3"	5.1	81°	70°	108°	61°	50°	83°	52°	43°	73°
V-4102.9-2.0	2.9mm	2.0	1/3"	5.85	74°	63°	101°	54°	44°	74°	46°	38°	75°
V-4106.0-2.0	6.0mm	2.0	1/3"	7.8	40°	33°	57°	28°	22°	40°	23°	18°	33°
V-4108.0-2.5	8.0mm	2.5	1/3"	6.33	31°	25°	44°	27°	19°	37°	21°	17°	30°
V-4112-2.0	12.0mm	2.0	1/3"	9.1	20°	17°	30°	18°	13°	25°	14°	11°	20°

High Resolution Miniature Glass Lenses

4400 Series High Resolution Miniature Fixed Glass Lenses

The **4400 series lenses** are designed and manufactured with the utmost precision. The 4400 series lenses have improved image quality to maximize capability and performance for a variety of applications. This series has M12 x 0.5 barrel thread and they are compatible with most Marshall cameras. The V-LH04 lens holder can be used for OEM applications. Custom designed metal or plastic lens holders available for OEM applications. Please contact our technical staff regarding your application.



Specifications - 4400 Series High Resolution Miniature Glass Lenses

Part No.	Focal Length	Relative Aperture	Sensing Area	Back Focal Length	Angular Field of View					
					1/3" CCD			1/4" CCD		
					(H)	(V)	(D)	(H)	(V)	(D)
V-4402.1-2.5-HR	2.1mm	2.5	1/3"	4.251	132.3°	102.0°	165.7°	-	-	-
V-4402.3-2.5-HR	2.3mm	2.5	1/3"	5.2	125.8°	97.3°	158.3°	91.9°	69.1°	117.1°
V-4402.5-2.5-HR	2.5mm	2.5	1/3"	5.04	113.4°	85.9°	142.7°	83.3°	62.3°	103.9°
V-4402.75-2.0-HR	2.75mm	2.0	1/3"	6.07	113.7°	82.3°	153.0°	82.3°	61.9°	104.0°
V-4403.0-2.0-HR	3.0mm	2.0	1/3"	5.67	94.4°	69.5°	126.0°	69.9°	51.7°	88.2°
V-4404.3-1.8-HR	4.3mm	1.8	1/3"	6.16	73.7°	47.3°	83.1°	49.2°	36.0°	61.1°
V-4405.6-2.0-HR	5.6mm	2.0	1/3"	8.07	51.4°	36.9°	65.3°	38.8°	28.9°	48.5°
V-4408.0-2.0-HR	8.0mm	2.0	1/3"	7.6	33.8°	25.7°	43.0°	24.8°	18.2°	31.35°
V-4412.0-2.0-HR	12mm	2.0	1/3"	6.7	22.2°	16.3°	28.0°	17.1°	12.6°	21.2°
V-4416.0-1.2-HR	16mm	1.2	1/3"	7.2	17.2°	13.0°	21.0°	-	-	-

1.3 MegaPixel 1/2 inch CS-Mount and M14 Mount Glass Lenses

MegaPixel resolution for security, robotics, imaging, machine vision, OEM applications

4600 Series CS-Mount and M14 Mount 1.3 MegaPixel Lenses



The **4600 Series MegaPixel lenses** are designed for full 1.3MP 1/2" image sensor resolution. High-quality glass optics produce superior image quality. Standard in-stock CS-Mount models without IR-cut filter for monochrome sensors and 650nm IR-cut filter models for color sensors. All optical surfaces have Marshall Broad Band Anti-Reflective (BBAR) coating. Custom design MegaPixel lens models available for OEM applications. Please contact our technical staff regarding OEM applications.

V-46-xx-xx 1.3MP CS-Mount and OEM Special Order M14 models

Part No.		650nm IR-Cut Filter	Focal Length	Relative Aperture	Sensing Area	Optical BFL		Optical Elements	Angular Field of View			Minimum Object Distance
CS-Mount	M14 x 0.5 Mini-Mount					CS-Mount	M14 x 0.5 Mini-Mount		(H)	(V)	(D)	
V-4604-CS	V-4604.0-2.0-M14	No	4.0mm	F2.0	1/2" MP	7.4mm	7.4mm	6	95.0°	71.6°	118.2°	40mm
V-4604-CS-IRC	V-4604.0-2.0-IRC-M14	Yes	4.0mm	F2.0	1/2" MP	7.4mm	7.4mm	6	95.0°	71.6°	118.2°	40mm
V-4606-CS	V-4606.0-2.0-M14	No	6.0mm	F2.0	1/2" MP	10.7mm	10.7mm	6	62.2°	47.2°	78.5°	40mm
V-4606-CS-IRC	V-4606.0-2.0-IRC-M14	Yes	6.0mm	F2.0	1/2" MP	10.7mm	10.7mm	6	62.2°	47.2°	78.5°	40mm
V-4608-CS	V-4608.0-1.8-M14	No	8.0mm	F1.8	1/2" MP	8.6mm	8.6mm	6	44.8°	33.6°	56.0°	40mm
V-4608-CS-IRC	V-4608.1.8-IRC-M14	Yes	8.0mm	F1.8	1/2" MP	8.6mm	8.6mm	6	44.8°	33.6°	56.0°	40mm
V-4612-CS	V-4612.0-2.0-M14	No	12.0mm	F2.0	1/2" MP	10.97mm	10.97mm	6	30.7°	22.9°	39.1°	40mm
V-4612-CS-IRC	V-4612.0-2.0-IRC-M14	Yes	12.0mm	F2.0	1/2" MP	10.97mm	10.97mm	6	30.7°	22.9°	39.1°	40mm

3 MegaPixel 1/2 inch CS-Mount and M14 Mount Glass Lenses



V-3MP-xxxx 3MP CS-Mount and OEM Special Order M14 models

Part No.		650nm IR-Cut Filter	Focal Length	Relative Aperture	Sensing Area	Optical BFL		Optical Elements	Angular Field of View			Minimum Object Distance
CS-Mount	M14 x 0.5 Mini-Mount					CS-Mount	M14 x 0.5 Mini-Mount		(H)	(V)	(D)	
V-3MP-4.0-2.0-CS	V-3MP-4.0-2.0-M14	No	4.0mm	F2.0	1/2" MP	7.4mm	7.4mm	6	95.0°	71.6°	118.2°	40mm
V-3MP-4.0-2.0-IRC-CS	V-3MP-4.0-2.0-IRC-M14	Yes	4.0mm	F2.0	1/2" MP	7.4mm	7.4mm	6	95.0°	71.6°	118.2°	40mm
V-3MP-6.0-2.0-CS	V-3MP-6.0-2.0-M14	No	6.0mm	F2.0	1/2" MP	10.7mm	10.7mm	6	62.2°	47.2°	78.5°	40mm
V-3MP-6.0-2.0-IRC-CS	V-3MP-6.0-2.0-IRC-M14	Yes	6.0mm	F2.0	1/2" MP	10.7mm	10.7mm	6	62.2°	47.2°	78.5°	40mm
V-3MP-8.0-1.8-CS	V-3MP-8.0-1.8-M14	No	8.0mm	F1.8	1/2" MP	8.6mm	8.6mm	6	44.8°	33.6°	56.0°	40mm
V-3MP-8.0-1.8-IRC-CS	V-3MP-8.0-1.8-IRC-M14	Yes	8.0mm	F1.8	1/2" MP	8.6mm	8.6mm	6	44.8°	33.6°	56.0°	40mm
V-3MP-12.0-2.0-CS	V-3MP-12.0-2.0-M14	No	12.0mm	F2.0	1/2" MP	10.97mm	10.97mm	6	30.7°	22.9°	39.1°	40mm
V-3MP-12.0-2.0-IRC-CS	V-3MP-12.0-2.0-IRC-M14	Yes	12.0mm	F2.0	1/2" MP	10.97mm	10.97mm	6	30.7°	22.9°	39.1°	40mm

5 MegaPixel 1/2 inch CS-Mount and M14 Mount Glass Lenses



V-5MP-xx-xx 5MP CS-Mount and OEM Special Order M14 models

Part No.		650nm IR-Cut Filter	Focal Length	Relative Aperture	Sensing Area	Optical BFL		Optical Elements	Angular Field of View			Minimum Object Distance
CS-Mount	M14 x 0.5 Mini-Mount					CS-Mount	M14 x 0.5 Mini-Mount		(H)	(V)	(D)	
V-5MP-3.5-1.8-CS	V-5MP-3.5-1.8-M14	No	3.5mm	F1.8	1/2" MP	6.4mm	6.4mm	7	97.2°	71.6°	126.6°	40mm
V-5MP-3.5-1.8-IRC-CS	V-5MP-3.5-1.8-IRC-M14	Yes	3.5mm	F1.8	1/2" MP	6.4mm	6.4mm	7	97.2°	71.6°	126.6°	40mm
V-5MP-5.1-1.8-CS	V-5MP-5.1-1.8--M14	No	5.1mm	F1.8	1/2" MP	7.4mm	7.4mm	7	65.1°	48.5°	82.3°	40mm
V-5MP-5.1-1.8-IRC-CS	V-5MP-5.1-1.8-IRC-M14	Yes	5.1mm	F1.8	1/2" MP	7.4mm	7.4mm	7	65.1°	48.5°	82.3°	40mm
V-5MP-8.4-1.8-CS	V-5MP-8.4-1.8--M14	No	8.4mm	F1.8	1/2" MP	6.2mm	6.2mm	8	46.0°	36.0°	57.0°	40mm
V-5MP-8.4-1.8-IRC-CS	V-5MP-8.4-1.8-IRC-M14	Yes	8.4mm	F1.8	1/2" MP	6.2mm	6.2mm	8	46.0°	36.0°	57.0°	40mm
V-5MP-10.1-1.8-CS	V-5MP-10.1-1.8-M14	No	10.1mm	F1.8	1/2" MP	9.2mm	9.2mm	6	33.3°	24.7°	42.6°	40mm
V-5MP-10.1-1.8-IRC-CS	V-5MP-10.1-1.8-IRC-M14	Yes	10.1mm	F1.8	1/2" MP	9.2mm	9.2mm	6	33.3°	24.7°	42.6°	40mm

4500 Series Economy C-Mount Lenses

These 4500 series lenses provide maximum performance for auto-shutter cameras not needing a manual iris lens. Lenses are made from high quality glass elements for maximum performance. The 4500 series lenses are C-mount lenses with manual focus.



Specifications - 4500 Series Economy C-Mount Lenses

Part No.	Specs	Field of View 1/2" format	(H x V in Degrees) 1/3" format
V-4504ML	4.0mm, f2.5	-	62 x 50
V-4508	8.0mm, f1.3	40 x 28	31 x 22
V-4508-2.8	8.0mm, f2.8	40 x 28	31 x 22
V-4512	12mm, f2.0	28 x 22	22 x 12
V-4516	16mm, f1.6	20 x 16	12 x 9

140mm F1.0 / ULTRA - LOW LIGHT LENS



Low light image performance for law enforcement, military, security, covert surveillance, and other applications requiring low-light imaging

The 140mm focal length F1.0 aperture lens provides excellent imaging in near zero ambient light conditions when used with a low lux camera. Low light performance is comparable to military amplified light scope devices and provides higher image quality. This model features Heavy Duty design and build quality.

Specifications - Model# V-140-1.0	
Focal Length	140mm
Relative Aperture	F1.0
Angular Field of View	1/3" : 2.0° H x 1.5° V 1/2" : 3.0° H x 2.0° V
Lens Mount	CS
Focus	Manual
Iris	Manual
Operating Temperature	-10° C ~ +40° C
Lens Dimensions	230mm x 135mm x 90mm
Weight	5000 grams



09:18am at 350 feet



12:17pm at 350 feet



08:32pm at 1000 feet



11:09pm at 1000 feet



02:12am at 1000 feet

Images captured using Wattec 232 day/night camera

300mm F3.75 / TELEPHOTO LENS

Specifications - Model# V-300-3.75	
Focal Length	300mm
Relative Aperture	F3.75
Angular Field of View	1/3" : ~0.88° H x ~0.66° V 1/2" : ~1.20° H x ~0.80° V
Lens Mount	CS
Focus	Manual
Iris	Manual
Operating Temperature	-10° C ~ +40° C
Lens Dimensions	350mm x ø95mm
Weight	~ 4080 grams

Long 300mm telephoto focal length at distance of 1000ft (300m) provides 21ft (6.5m) horizontal scene size when used with 1/2" sensor camera. The lens system with F3.75 aperture provides high image quality in all usable light conditions. This model also features Heavy Duty design and build quality.



09:18am at 1000 feet



12:22pm at 1000 feet



01:09pm at 1000 feet



08:48pm at 1000 feet



10:31pm at 1000 feet

Images captured using Wattec 232 day/night camera

V-ZL120-1200 120-1200mm Zoom Lens

- Up to 150x magnification on 1/3" CCD sensor
- Variable f-stop adjustment
- Allows fine adjustments to back focus
- Includes eyepiece to use as telescope

For the ultimate in surveillance lenses, the V-ZL120-1200 offers a CS-Mount and standard 1/4" mount on its center ring for tripod mounting. Designed for 1/3 inch CCD cameras. The front ring adjusts the zoom, center ring adjusts iris, and back ring allows back focus adjustment. Lens is 17 inches long and weighs just 3.3 pounds.



Features, specifications, pricing and dimensions are subject to change without notice. Physical appearance of products may vary slightly from images shown in this catalog. Please visit www.mars-cam.com for updates and information.