

ATX High Security

ATEX (EN60079) & IECEx Reader
NXP - DESFire EV1 chips



High Security access control in explosive environments

The ATX 13.56 MHz is a high-security ATEX & IECEx certified proximity reader for all your access control requirements in explosive environments. STid's range of ATX RFID products can be used to meet all your contactless identification needs in the chemical and petrochemical industries, in refineries or in nuclear power plants.

The ATX reader boasts the latest security technology from STid, ensuring secure, confidential communications with full data integrity between the tag, reader and management system.

► ATEX Certification

ATX High Security readers are ATEX (EN60079) & IECEx certified, in accordance with the two relevant European Directives (99/92/EC and 94/9/EC) and are designed for personal identification applications in explosive environments. The EX II 2 GD IP66 explosion-proof casing is well-suited to the chemical, petrochemical and nuclear industries, among others.

► High security

The new generation of ATX High Security readers supports the latest Mifare® contactless technologies and their new data protection and security features. They use all the new and possible security algorithms of these chips: Crypto1, DES, TDES, AES, etc.

► Card-based reader configuration

ATX read-only devices can be configured using configuration cards. These cards are used to configure the settings for user cards with regard to security (such as key management) and operation (protocol, LEDs, etc.).

► Multi-technology, evolutive

ATX readers are compliant with ISO14443 type A & 3B, ISO18092 standards.

They support simultaneously the NXP Mifare chips: Ultralight, Classic (1ko, 4ko), Ultralight C, Mifare Plus (S and X, 2ko and 4ko), DESFire and DESFire EV1 - As well as special products like NFC transactions.

With this multiple standard reading capacity, the reader is ready to answer easily cases of building extension, security evolution or migration.

The reader's firmware can be upgraded on-site with the serial communication to benefit technological evolutions (read/write version).

► Marking

EC type examination certificate:
BK1 08 ATEX 0048
Type approved: GUB
Ex II 2 GD
(G: Gas / D: Dust)
Ex d IIC T5
Ex tD A21 T100°C IP66



ATX High Security

ATEX (EN60079) & IECEX Reader - DESFire EV1

Specifications

Operating frequency/standards	13.56 MHz. ISO14443A, ISO14443-3B (PUP1), ISO18092																		
Chip compatibility	Mifare Ultralight®, Mifare Ultralight® C, Mifare Classic®, Mifare Plus®, Mifare DESFire®, Mifare DESFire EV1®, NFC, SMART MX																		
Functions	Read only: CSN, private ID (sector/file) or secure protocol (Secure Plus) Read write: SSCP																		
Reading distance*	Up to 4 cm with a Mifare Plus® card / DESFire EV1®																		
Communication interfaces	TTL - Wiegand - Data/Clock (Ciphred Wiegand/S31) / RS232 / RS485																		
Connections	2 cables glands PE PAP-R0 M20, for blinded cable ext. 10-19mm Internal block junction 9 x 2,5 mm ²																		
Bicolor led	Bicolore leds (colors: green, red, orange) Card configuration and external command (0V) in R31/S31 - Controlled by soft W32/W33																		
Power supply	5 VDC to 24 VDC																		
Power requirement	Typical 80 mA/12V																		
Matériau	Alluminium alloy & stainless steel, metallic blue paint																		
Dimensions	270 x 310 x 180 mm																		
Weight	13,5 kg																		
Operating temperatures	- 20°C to + 70°C - Inside / outside use																		
Résistance	IP 66																		
Mounting	Wall mount: 4 brackets included - Screw diameter 11mm																		
Certification	CE (ETS 300-330) & FCC ATEX (EN60079) & IECEX																		
Marking	EC type examination certificate: BKI 08 ATEX 0048 Type approved: GUB Ex II 2 GD (G: Gas / D: Dust) Ex d IIC T5 Ex tD A21 T100°C IP66																		
Part number	<table border="0"> <tr> <td>CSN read-only - TTL:</td> <td>ATX-R31-E/103-xx/7</td> </tr> <tr> <td>Secure read-only - TTL:</td> <td>ATX-R31-E/PH5-xx/7</td> </tr> <tr> <td>Secure read-only - TTL - Secure Plus:</td> <td>ATX-S31-E/PH5-xx/7</td> </tr> <tr> <td>Secure read-only - RS232:</td> <td>ATX-R32-E/PH5-5AB/7</td> </tr> <tr> <td>Secure read-only - RS232 - Secure Plus:</td> <td>ATX-S32-E/PH5-5AB/7</td> </tr> <tr> <td>Secure read-only - RS485:</td> <td>ATX-R33-E/PH5-7AB/7</td> </tr> <tr> <td>Secure read-only - RS485 - Secure Plus:</td> <td>ATX-S33-E/PH5-7AB/7</td> </tr> <tr> <td>Read Write - RS232:</td> <td>ATX-W32-E/PH5-5AA/7</td> </tr> <tr> <td>Read Write - RS485:</td> <td>ATX-W33-E/PH5-7AA/7</td> </tr> </table>	CSN read-only - TTL:	ATX-R31-E/103-xx/7	Secure read-only - TTL:	ATX-R31-E/PH5-xx/7	Secure read-only - TTL - Secure Plus:	ATX-S31-E/PH5-xx/7	Secure read-only - RS232:	ATX-R32-E/PH5-5AB/7	Secure read-only - RS232 - Secure Plus:	ATX-S32-E/PH5-5AB/7	Secure read-only - RS485:	ATX-R33-E/PH5-7AB/7	Secure read-only - RS485 - Secure Plus:	ATX-S33-E/PH5-7AB/7	Read Write - RS232:	ATX-W32-E/PH5-5AA/7	Read Write - RS485:	ATX-W33-E/PH5-7AA/7
CSN read-only - TTL:	ATX-R31-E/103-xx/7																		
Secure read-only - TTL:	ATX-R31-E/PH5-xx/7																		
Secure read-only - TTL - Secure Plus:	ATX-S31-E/PH5-xx/7																		
Secure read-only - RS232:	ATX-R32-E/PH5-5AB/7																		
Secure read-only - RS232 - Secure Plus:	ATX-S32-E/PH5-5AB/7																		
Secure read-only - RS485:	ATX-R33-E/PH5-7AB/7																		
Secure read-only - RS485 - Secure Plus:	ATX-S33-E/PH5-7AB/7																		
Read Write - RS232:	ATX-W32-E/PH5-5AA/7																		
Read Write - RS485:	ATX-W33-E/PH5-7AA/7																		



*Caution: information about the distance of communication: measured from the centre of the antenna, depending on the type of identifier, size of the identifier, operating environment of the reader, power supply voltage and reading functions (secure reading).



Mifare Plus / DESFire EV1 enrollment, programming and development kits available, contact-us.

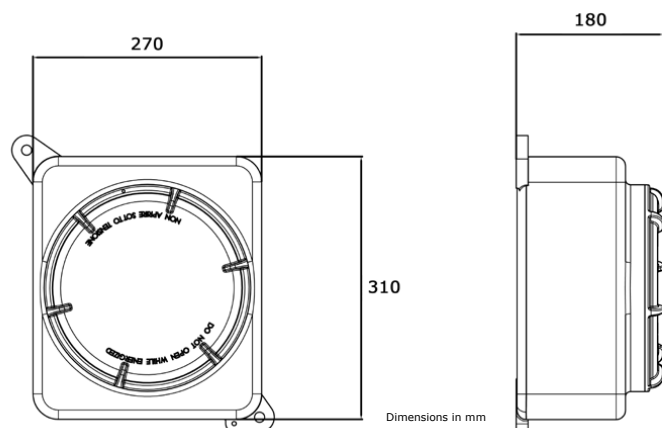

Approved STid reseller

Legal statements: STid is a trademark of STid SA. Mifare® is a NXP trademark. All other trademarks are property of their respective owners. This document is the exclusive property of STid. STid reserves the right to stop any product or service for any reason and without any liability - Noncontractual photographs

Headquarters

20 Parc d'activités des Pradeaux
13850 Gréasque, FRANCE
☎ +33 (0)4 42 12 60 60
✉ +33 (0)4 42 12 60 61
✉ info@stid.com

Paris IDF Agency

Immeuble Le Fahrenheit
28, rue de la Redoute
92260 Fontenay-aux-Roses, FRANCE
☎ +33 (0)1 43 50 11 43
✉ +33 (0)1 43 50 27 37
✉ info@stid.com

STid America

Oxford # 30 Colonia Juárez
CP.06600 Delegación. Cuauhtemoc
México D.F.
☎ +52 (55) 52 56 47 06
✉ +52 (55) 52 56 47 07
✉ info@stid-america.com