

TCB Series Autofocus IP Zoom Module



TCB-2244F(2MP 40X)
TCB-2844F(4K 40X)



TCB-2240F(2MP 40X)
TCB-2340F(3MP 40X)
TCB-2840F(4K 40X)



TCB-1236A(2MP 36X)



TCB-3230F(2MP 30X)

TCB-1236A(2MP 36X)
TCB-3230F(2MP 30X)
TCB-2240F(2MP 40X)
TCB-2244F(2MP 44X)
TCB-2340F(3MP 40X)
TCB-2840F(4K 40X)
TCB-2844F(4K 44X)

Fast & Accurate Focusing Performance

In low-light conditions, TCB series can accurately focus on complex photo scenes based on large amounts of data accumulation from various experiences.

Focus

PTZ Control: Focus Near, Focus Far, Auto Focus

Minimum Focus Length: Adjust minimum length of focus between 10cm to 10m

Advanced Focus settings:

Auto focus after zoom control, One shot AF after PTZ, AF sensitivity – adjust sensitivity of auto focus

AF area (Auto, Full, Center, Peak)

Wide Range of Zoom Ratio

With various optical x36/x40/x44, it's available to monitor any objects in long distance. Image stabilizer and optical/digital zoom are combined to enhance picture quality while maintaining the original horizontal angle of view. This ensures no compromise in image size, and reduces blurring.

De-fog

When the surrounding area of the subject is foggy and low contrast, the defog mode will reduce the effects of the fog and make the subject appear clearer



Foggy Filter ON

Foggy Filter OFF

Day & Night Mode

The TCB series deliver color images during the day. As light diminishes below a certain level, the camera can automatically switch to night mode (Black and White mode), removing the IR-cut filter to boost sensitivity for clear pictures in near-darkness to maintain good image quality. (Auto, Day, Night, External Sensor)



IR LED ON

IR LED OFF

Powerful Encoding Performance

The latest H.265 codec is available with various application such as IVS(Intelligent Video System), LPR(License Plate Recognition) and AI Solution.



Various PTZ Protocol

More than 40 protocols including Visca, Pelco D/P are included for PT system or Speed Dome Camera that allows developers to integrate the TCS Series with their systems easily.

Capture crisp, clear Full-HD and 4K images

The high-performance Sony image sensor achieves superb Full-HD and 4K picture quality, even in lowlight environments. Progressive scanning assures smoother pictures with reduced blur – ideal for capturing the detail in moving images.

Image Enhancement

AE: A variety of AE functions are available for optimal output of subjects in lighting conditions that range from low to high (Auto, Flat, Center)

AWB: Auto Tracing White, Auto White, Manual Mode

BLC: Adjusts exposure of the entire image to properly expose the subject in foreground.

DIS: Reduces the level of blur or distortion in pictures that can result from unsteady or shaky movement.

IRIS Mode: Based on zoom magnification, close IRIS when zoom in or when low exposure (able to set limit F. Number)



Wide Dynamic Range

Wide Dynamic Range

Wide Dynamic Range mode is image processing technology which gives the ability to see clear, detailed images in high-contrast or backlit environments.



Privacy Zone Masking

Privacy Zone masking protects private objects and areas such as house windows, entrances, and exits which are within the camera's range of vision but not subject to surveillance. Privacy zone masking can be masked on the monitor to protect privacy. Mask can be displayed on 8 regions per screen and individual on/off is available.

Extreme low light performance

The high performance image sensors provide superb Full HD and 4K picture quality even in low light environment.



TRUE Light ON

TRUE Light OFF

Visibility Enhancer

Depending on the imaging scene, the Visibility Enhancer function makes the darker part of a camera image brighter, and automatically correct brightness and contrast to show bright parts clearly.

TCB-1236A Specifications

Basic Specifications	
Image Sensor	1/2" Sony CMOS Sensor
Minimum Illumination	Color : 0.048 Lux at 1/30sec, 50IRE BW : 0.001 Lux at 1/30sec, 50IRE
Analog Gain / Digital Max Gain	1 to 30
Shutter Speed	1/1 to 1/100000
Maximum Aperture Ratio	F1.4 ~ F4.9
Defog	YES
Noise Reduction	2D, 3D
Gamma	0, 1, 2, Auto(Normal), Auto(Clear), Auto(Bright), Auto(Fine)
Wide Dynamic Range	Level 1 to Level 7
White Balance	Auto Tracing White, Auto White, Manual
AE (Auto Exposure Mode)	Auto, Flat, Spot, Center
Lens (wide to tele)	36x optical zoom ; f= 6 mm to 216mm, F1.5 to F4.8
Digital Zoom	16x
Angle of View	Horizontal : 58.5°(wide) ~ °2.1(tele)
Minimum Focus Length	1 m to 10 m
Video	
Compression	H.265/H.264/MJPEG
Frame rate	Max 60fps @ 1920x1080
Bitrate	Primary : 32Kbps ~ 16Mbps, Secondary x3 : 32Kbps ~ 4Mbps
Resolution	352x240 ~ 1920x1080
Streaming	Primary : H.265/H.264, Secondary x 3 : H.265/H.264/MJPEG
Burn-in OSD	Multi-lingual
Audio	
Compression	G.711 / AAC
Sampling rate	G.711 : 8 KHz, AAC : 32 kHz / 44.1 kHz / 48 kHz
Bitrate	G.711 : 64Kbps, AAC: 64Kbps/128Kbps
Streaming	G.711 : Full-duplex, AAC : Full-duplex
Input/Output	1 x Line-In (mono), 1 x Line-Out (mono) - IN / OUT Connector : 0.4mm PITCH CONNECTOR FOR 30pin MICRO COAXIAL CABLE (KEL)
Network	
Protocol	IPv4/v6, TCP, UDP, IGMP(Multicast), ICMP, DHCP, HTTP, HTTP, FTP, SNMP, SMTP, UPnP, WS-Discovery, Zero Configuration, NTP, SRT, MPEG-TS, RTP, RTSP, RTMP, DDNS
Security	Password protection, IP address filtering, HTTPS encryption, SRT
API	Truen protocol/SDK, ONVIF, PSIA
Interface	Ethernet 10/100/1000base-T / Connector : 1.25mm Conn - Connector : 1.25mm PITCH wire to board CONNECTOR (8pin of 12pin)
General	
Power Supply	Min DC12V/1.5A
Power Consumption	DC12V: Max 4.5W
Operating Temperature	-10°C ~ 50°C (14°F ~ 122°F)
Storage Temperature	-10°C ~ 50°C (14°F ~ 122°F)
Operating Humidity	20% ~ 80% RH
Storage Humidity	20% ~ 80% RH
Edge Storage	SD/SDHC/SDXC slot (Max 256GB) / Connector : Micro-Coaxial
Dimensions (W x H x D)	55.5mm X 124.3mm X 66.5mm
Weight	356.4g

Dimensions

< Front >

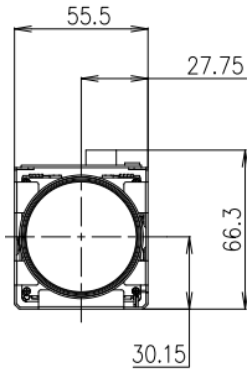

< Top >

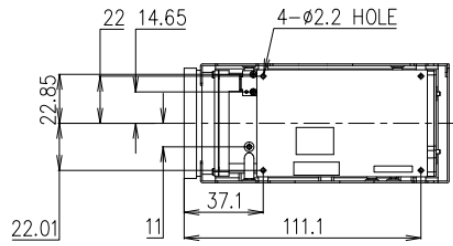

< Bottom >

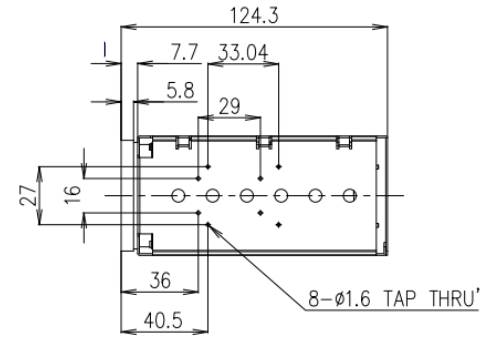

< Rear >

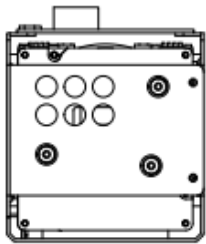

< Right side >

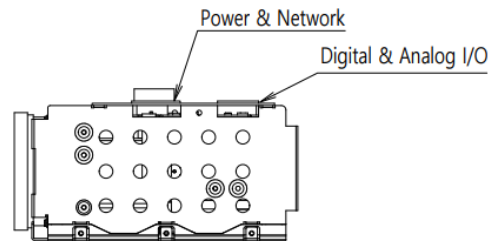

< Left side >

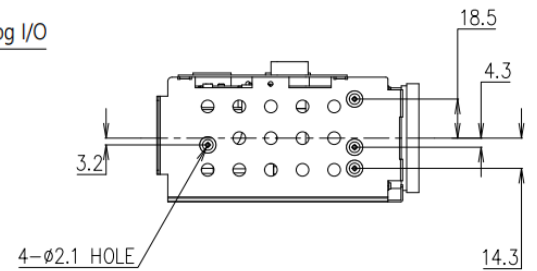

Pin Assignment & Connector

ROM-J4							ROM-J1				
Pin No.	Signal	Dir	Description	Pin No.	Signal	Dir	Description	Pin No.	Signal	Dir	Description
1	EXT_RTX+	I/O	RS-485 +	16	5V	PWR	DC 5V Output (Max 100mA)	1	NETWORK_D-	IO	Ethernet Negative Data 4
2	EXT_RTX-	I/O	RS-485 -	17	Reserved	I/O	Reserved	2	NETWORK_D+	IO	Ethernet Positive Data 4
3	AC_IN_L	I	Audio Line input	18	Reserved	I/O	Reserved	3	NETWORK_C-	IO	Ethernet Negative Data 3
4	AC_OUT_L	O	Audio Line output	19	GND	PWR	Ground	4	NETWORK_C+	IO	Ethernet Positive Data 3
5	IP_RESET	I	Factory reset Input(Active Low)	20	Reserved GPIO0	I/O	GPO(For Alarm Output, 3.3V Signal output)	5	NETWORK_B-	IO	Ethernet Negative Data 2
6	DAC_CVBS	O	CVBS output	21	Reserved GPIO1	I/O	GPI(For Sensor Input, 3.3V Signal input)	6	NETWORK_B+	IO	Ethernet Positive Data 2
7	Reserved	O	Reserved	22	3.3V	PWR	DC 3.3V Output (Max 100mA)	7	NETWORK_A-	IO	Ethernet Negative Data 1
8	Reserved	O	Reserved	23	3.3V	PWR	DC 3.3V Output (Max 100mA)	8	NETWORK_A+	IO	Ethernet Positive Data 1
9	Reserved	O	Reserved	24	SDIO0_DETE CT	I	SDIO 0 card detection signal, active low	9	VIN	PWR	Supply Voltage DC12V
10	Reserved	I	Reserved	25	SDIO0_CLK	O	SDIO 0 output working clock for the card	10	VIN	PWR	Supply Voltage DC12V
11	INTER_Tx1	O	Connect to INTER_Rx2	26	SDIO0_CMD	I/O	SDIO 0 command	11	GND	PWR	Ground
12	INTER_Rx1	I	Connect to INTER_Tx2	27	SDIO0_DATA 0	I/O	SDIO 0 data 0	12	GND	PWR	Ground
13	INTER_Tx2	O	Connect to INTER_Rx1	28	SDIO0_DATA 1	I/O	SDIO 0 data 1				
14	INTER_Rx2	I	Connect to INTER_Tx1	29	SDIO0_DATA 2	I/O	SDIO 0 data 2				
15	5V	PWR	DC 5V Output (Max 100mA)	30	SDIO0_DATA 3	I/O	SDIO 0 data 3				

Accessories

- ▶ Micro Coaxial Cable
- ▶ Interface Board

* For detailed information, please contact us at os@truen.co.kr

TCB-3230F Specifications

Basic Specifications	
Image Sensor	1/2.8 Sony CMOS Sensor
Minimum Illumination	Color : 0.06 Lux at 1/15sec, 50IRE BW : 0.0003 Lux at 1/15sec, 50IRE
Analog Gain / Digital Max Gain	1 to 30
Shutter Speed	1/1 to 1/100000
Maximum Aperture Ratio	F1.3 ~ F4.8
Defog	YES
Noise Reduction	2D, 3D
Gamma	0, 1, 2, Auto(Normal), Auto(Clear), Auto(Bright), Auto(Fine)
Wide Dynamic Range	Level 1 to Level 7
White Balance	Auto Tracing White, Auto White, Manual
AE (Auto Exposure Mode)	Auto, Flat, Spot, Center
Lens (wide to tele)	30x optical zoom ; f= 5.2 mm to 156mm, F1.3 to F4.8
Digital Zoom	16x
Angle of View	Horizontal : 59.5°(wide) ~ °3.58(tele) / Vertical : 34.7°(wide) ~ °2(tele) / Diagonal : 67.1°(wide) ~ °4.1(tele)
Minimum Focus Length	1 m to 10 m
Video	
Compression	H.265/H.264/MJPEG
Frame rate	Max 60fps @ 1920x1080
Bitrate	Primary : 32Kbps ~ 16Mbps, Secondary x3 : 32Kbps ~ 4Mbps
Resolution	352x240 ~ 1920x1080
Streaming	Primary : H.265/H.264, Secondary x 3 : H.265/H.264/MJPEG
Bitrate Control	CBR / VBR / Hybrid / Adaptive CBR / Smart CBR
Burn-in OSD	Multi-lingual
Audio	
Compression	G.711 / AAC
Sampling rate	G.711 : 8 KHz, AAC : 32 kHz / 44.1 kHz / 48 kHz
Bitrate	G.711 : 64Kbps, AAC: 64Kbps/128Kbps
Streaming	G.711 : Full-duplex, AAC : Full-duplex
Network	
Protocol	IPv4/v6, TCP, UDP, IGMP(Multicast), ICMP, DHCP, HTTP, HTTP, FTP, SNMP, SMTP, UPnP, WS-Discovery, Zero Configuration, NTP, SRT, MPEG-TS, RTP, RTSP, RTMP, DDNS
Security	Password protection, IP address filtering, HTTPS encryption, SRT
API	Truen protocol/SDK, ONVIF, PSIA
Interface	Ethernet 10/100/1000base-T / Connector : 1.25mm Conn - Connector : 1.25mm PITCH wire to board CONNECTOR (8pin of 12pin)
PTZ Control Protocol	40 types of control protocol including Pelco-D, Pelco-P, Visca
PTZ functionalities	Preset (500), Pattern (4), Swing (8), Group (8), Auto parking
General	
Power Supply	Min DC12V/2A
Power Consumption	DC12V: Max 5.4W
Operating Temperature	-10°C ~ 50°C (14°F ~ 122°F)
Storage Temperature	-10°C ~ 50°C (14°F ~ 122°F)
Operating Humidity	20% ~ 80% RH
Storage Humidity	20% ~ 80% RH
Edge Storage	SD/SDHC/SDXC slot (Max 256GB) / Connector : Micro-Coaxial
Dimensions (W x H x D)	51.6mm X 61.1mm X 101.8mm
Weight	294.2g

Dimensions

< Front >

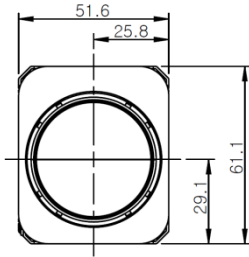

< Top >

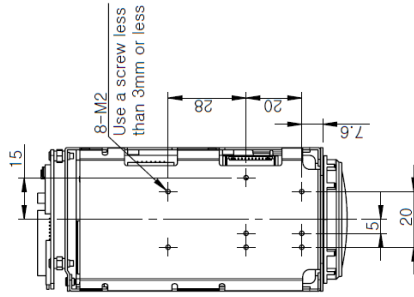

< Bottom >

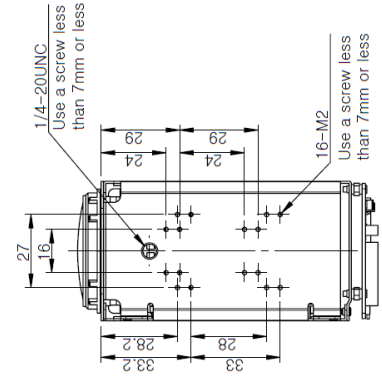

< Rear >

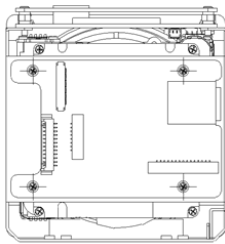

< Right side >

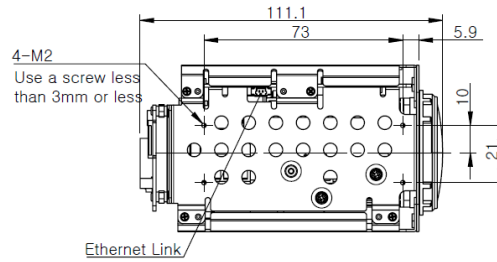

< Left side >

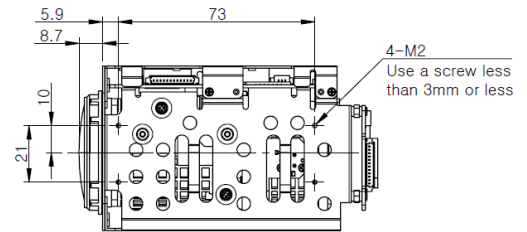

Pin Assignment & Connector

R31-J3				R31-J4			
Pin No.	Signal	Dir	Description	Pin No.	Signal	Dir	Description
1	EXT_RTX-	I/O	RS-485 -	1	NETWORK_A+	IO	Ethernet Positive Data 1
2	EXT_RTX+	I/O	RS-485 +	2	NETWORK_A-	IO	Ethernet Negative Data 1
3	IP_RESET	I	Factory reset Input(Active Low)	3	NETWORK_B+	IO	Ethernet Positive Data 2
4	Reserved	-	Reserved	4	NETWORK_B-	IO	Ethernet Negative Data 2
5	GND	PWR	Ground	5	NETWORK_C+	IO	Ethernet Positive Data 3
6	AC_OUT_L	O	Audio Line output	6	NETWORK_C-	IO	Ethernet Negative Data 3
7	GND	PWR	Ground	7	NETWORK_D+	IO	Ethernet Positive Data 4
8	AC_IN_L	I	Audio Line input	8	NETWORK_D-	IO	Ethernet Negative Data 4
9	GND	PWR	Ground				
10	ALARM_COM	O	Alarm signal				
11	ALARM_NO	O	Alarm signal				
12	SENSOR	I	Sensor signal				
13	GND	PWR	Ground				
14	DC12V	PWR	Supply Voltage				
15	DC12V	PWR	Supply Voltage				

TCB-2240F Specifications

Basic Specifications	
Image Sensor	1/2 Sony CMOS Sensor
Minimum Illumination	Color : 0.07 Lux at 1/15sec, 50IRE BW : 0 Lux at 1/15sec, 50IRE
Analog Gain / Digital Max Gain	1 to 30
Shutter Speed	1/1 to 1/100000
Maximum Aperture Ratio	F1.4 ~ F4.9
Defog	YES
Noise Reduction	2D, 3D
Gamma	0, 1, 2, Auto(Normal), Auto(Clear), Auto(Bright), Auto(Fine)
Wide Dynamic Range	Level 1 to Level 7
White Balance	Auto Tracing White, Auto White, Manual
AE (Auto Exposure Mode)	Auto, Flat, Spot, Center
Lens (wide to tele)	40x optical zoom ; f= 6.5mm to 260mm, F1.4 to F4.9
Digital Zoom	16x
Angle of View	Horizontal : 61.4°(wide) ~ °2.0(tele) / Vertical : 36.2°(wide) ~ °1.2(tele) / Diagonal : 68.9°(wide) ~ °2.3(tele)
Minimum Focus Length	1 m to 10 m
Video	
Compression	H.265/H.264/MJPEG
Frame rate	Max 60fps @ 1920x1080
Bitrate	Primary : 32Kbps ~ 16Mbps, Secondary x3 : 32Kbps ~ 4Mbps
Resolution	352x240 ~ 1920x1080
Streaming	Primary : H.265/H.264, Secondary x 3 : H.265/H.264/MJPEG
Bitrate Control	CBR / VBR / Hybrid / Adaptive CBR / Smart CBR
Burn-in OSD	Multi-lingual
Audio	
Compression	G.711 / AAC
Sampling rate	G.711 : 8 KHz, AAC : 32 kHz / 44.1 kHz / 48 kHz
Bitrate	G.711 : 64Kbps, AAC: 64Kbps/128Kbps
Streaming	G.711 : Full-duplex, AAC : Full-duplex
Network	
Protocol	IPv4/v6, TCP, UDP, IGMP(Multicast), ICMP, DHCP, HTTP, HTTP, FTP, SNMP, SMTP, UPnP, WS-Discovery, Zero Configuration, NTP, SRT, MPEG-TS, RTP, RTSP, RTMP, DDNS
Security	Password protection, IP address filtering, HTTPS encryption, SRT
API	Truen protocol/SDK, ONVIF, PSIA
Interface	Ethernet 10/100/1000base-T / Connector : 1.25mm Conn - Connector : 1.25mm PITCH wire to board CONNECTOR (8pin of 12pin)
PTZ Control Protocol	40 types of control protocol including Pelco-D, Pelco-P, Visca
PTZ functionalities	Preset (500), Pattern (4), Swing (8), Group (8), Auto parking
General	
Power Supply	Min DC12V/2A
Power Consumption	DC12V: Max 13.6 W
Operating Temperature	-10°C ~ 50°C (14°F ~ 122°F)
Storage Temperature	-10°C ~ 50°C (14°F ~ 122°F)
Operating Humidity	20% ~ 80% RH
Storage Humidity	20% ~ 80% RH
Edge Storage	SD/SDHC/SDXC slot (Max 256GB) / Connector : Micro-Coaxial
Dimensions (W x H x D)	73.4mm X 78.2mm X 152.6mm
Weight	681.6g

Dimensions

< Front >

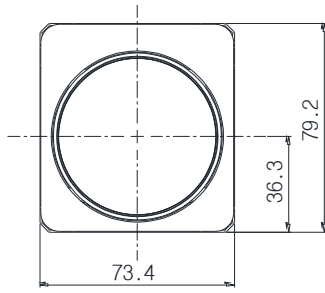

< Top >

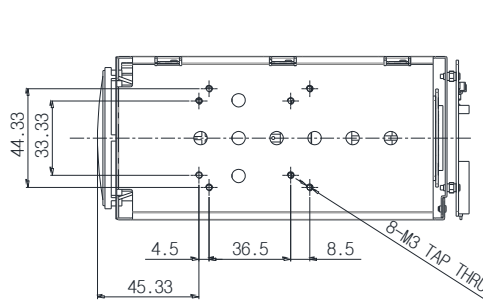

< Bottom >

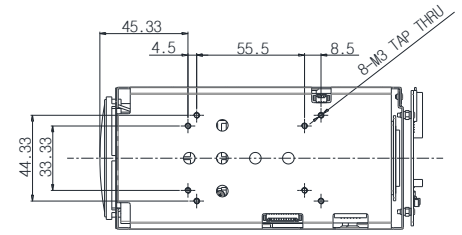

< Rear >

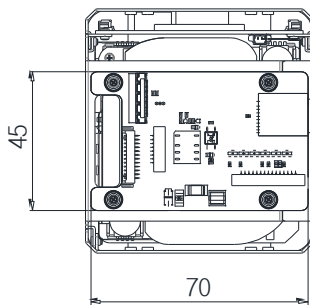

< Right side >

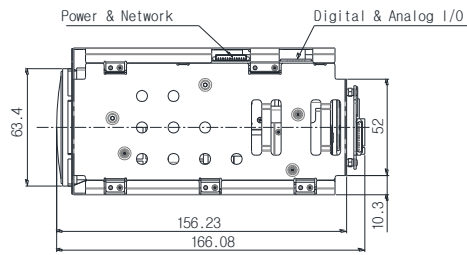

< Left side >

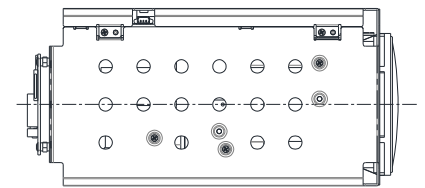

Pin Assignment & Connector

R31-J3				R31-J4			
Pin No.	Signal	Dir	Description	Pin No.	Signal	Dir	Description
1	EXT_RTX-	I/O	RS-485 -	1	NETWORK_A+	IO	Ethernet Positive Data 1
2	EXT_RTX+	I/O	RS-485 +	2	NETWORK_A-	IO	Ethernet Negative Data 1
3	IP_RESET	I	Factory reset Input(Active Low)	3	NETWORK_B+	IO	Ethernet Positive Data 2
4	Reserved	-	Reserved	4	NETWORK_B-	IO	Ethernet Negative Data 2
5	GND	PWR	Ground	5	NETWORK_C+	IO	Ethernet Positive Data 3
6	AC_OUT_L	O	Audio Line output	6	NETWORK_C-	IO	Ethernet Negative Data 3
7	GND	PWR	Ground	7	NETWORK_D+	IO	Ethernet Positive Data 4
8	AC_IN_L	I	Audio Line input	8	NETWORK_D-	IO	Ethernet Negative Data 4
9	GND	PWR	Ground				
10	ALARM_COM	O	Alarm signal				
11	ALARM_NO	O	Alarm signal				
12	SENSOR	I	Sensor signal				
13	GND	PWR	Ground				
14	DC12V	PWR	Supply Voltage				
15	DC12V	PWR	Supply Voltage				

TCB-2244F Specifications

Basic Specifications	
Image Sensor	1/2 Sony CMOS Sensor
Minimum Illumination	Color : 0.07 Lux at 1/15sec, 50IRE BW : 0 Lux at 1/15sec, 50IRE
Analog Gain / Digital Max Gain	1 to 30
Shutter Speed	1/1 to 1/100000
Maximum Aperture Ratio	F1.4 ~ F5.0
Defog	YES
Noise Reduction	2D, 3D
Gamma	0, 1, 2, Auto(Normal), Auto(Clear), Auto(Bright), Auto(Fine)
Wide Dynamic Range	Level 1 to Level 7
White Balance	Auto Tracing White, Auto White, Manual
AE (Auto Exposure Mode)	Auto, Flat, Spot, Center
Lens (wide to tele)	44x optical zoom ; f= 6.3mm to 278mm, F1.4 to F5.0
Digital Zoom	16x
Angle of View	Horizontal : 61.6°(wide) ~ °1.9(tele) / Vertical : 36.0°(wide) ~ °1.1(tele) / Diagonal : 69.5°(wide) ~ °2.2(tele)
Minimum Focus Length	1 m to 10 m
Video	
Compression	H.265/H.264/MJPEG
Frame rate	Max 60fps @ 1920x1080
Bitrate	Primary : 32Kbps ~ 16Mbps, Secondary x3 : 32Kbps ~ 4Mbps
Resolution	352x240 ~ 1920x1080
Streaming	Primary : H.265/H.264, Secondary x 3 : H.265/H.264/MJPEG
Bitrate Control	CBR / VBR / Hybrid / Adaptive CBR / Smart CBR
Burn-in OSD	Multi-lingual
Audio	
Compression	G.711 / AAC
Sampling rate	G.711 : 8 KHz, AAC : 32 kHz / 44.1 kHz / 48 kHz
Bitrate	G.711 : 64Kbps, AAC: 64Kbps/128Kbps
Streaming	G.711 : Full-duplex, AAC : Full-duplex
Network	
Protocol	IPv4/v6, TCP, UDP, IGMP(Multicast), ICMP, DHCP, HTTP, HTTP, FTP, SNMP, SMTP, UPnP, WS-Discovery, Zero Configuration, NTP, SRT, MPEG-TS, RTP, RTSP, RTMP, DDNS
Security	Password protection, IP address filtering, HTTPS encryption, SRT
API	Truen protocol/SDK, ONVIF, PSIA
Interface	Ethernet 10/100/1000base-T / Connector : 1.25mm Conn - Connector : 1.25mm PITCH wire to board CONNECTOR (8pin of 12pin)
PTZ Control Protocol	40 types of control protocol including Pelco-D, Pelco-P, Visca
PTZ functionalities	Preset (500), Pattern (4), Swing (8), Group (8), Auto parking
General	
Power Supply	Min DC12V/2A
Power Consumption	DC12V: Max 13.6 W
Operating Temperature	-10°C ~ 50°C (14°F ~ 122°F)
Storage Temperature	-10°C ~ 50°C (14°F ~ 122°F)
Operating Humidity	20% ~ 80% RH
Storage Humidity	20% ~ 80% RH
Edge Storage	SD/SDHC/SDXC slot (Max 256GB) / Connector : Micro-Coaxial
Dimensions (W x H x D)	73.3mm X 77.24mm X 173.65mm
Weight	724g

Dimensions

< Front >

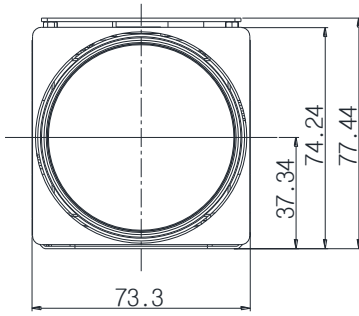

< Top >

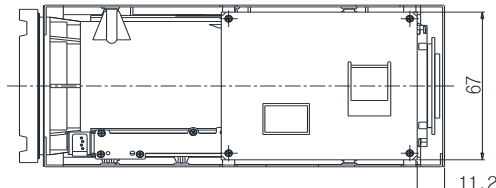

< Bottom >

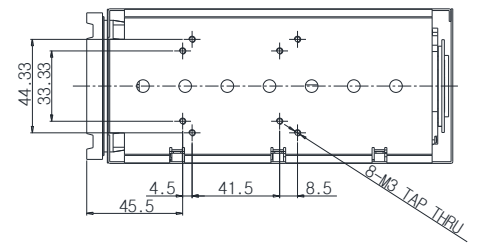

< Rear >

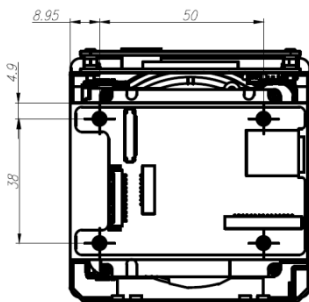

< Right side >

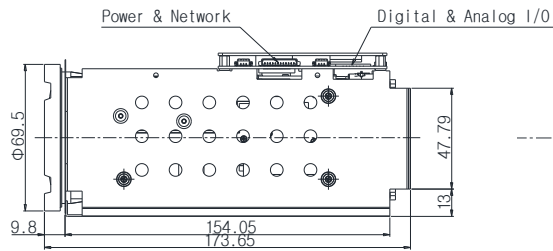

< Left side >

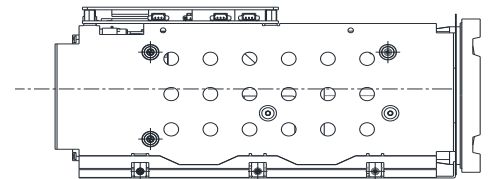

Pin Assignment & Connector

R31-J3				R31-J4			
Pin No.	Signal	Dir	Description	Pin No.	Signal	Dir	Description
1	EXT_RTX-	I/O	RS-485 -	1	NETWORK_A+	IO	Ethernet Positive Data 1
2	EXT_RTX+	I/O	RS-485 +	2	NETWORK_A-	IO	Ethernet Negative Data 1
3	IP_RESET	I	Factory reset Input(Active Low)	3	NETWORK_B+	IO	Ethernet Positive Data 2
4	Reserved	-	Reserved	4	NETWORK_B-	IO	Ethernet Negative Data 2
5	GND	PWR	Ground	5	NETWORK_C+	IO	Ethernet Positive Data 3
6	AC_OUT_L	O	Audio Line output	6	NETWORK_C-	IO	Ethernet Negative Data 3
7	GND	PWR	Ground	7	NETWORK_D+	IO	Ethernet Positive Data 4
8	AC_IN_L	I	Audio Line input	8	NETWORK_D-	IO	Ethernet Negative Data 4
9	GND	PWR	Ground				
10	ALARM_COM	O	Alarm signal				
11	ALARM_NO	O	Alarm signal				
12	SENSOR	I	Sensor signal				
13	GND	PWR	Ground				
14	DC12V	PWR	Supply Voltage				
15	DC12V	PWR	Supply Voltage				

Basic Specifications	
Image Sensor	1/1.8 Sony CMOS Sensor
Minimum Illumination	Color : 0.05 Lux at 1/15sec, 50IRE BW : 0.025 Lux at 1/15sec, 50IRE
Analog Gain / Digital Max Gain	1 to 30
Shutter Speed	1/1 to 1/100000
Maximum Aperture Ratio	F1.4 ~ F4.9
Defog	YES
Noise Reduction	2D, 3D
Gamma	0, 1, 2, Auto(Normal), Auto(Clear), Auto(Bright), Auto(Fine)
Wide Dynamic Range	Level 1 to Level 7
White Balance	Auto Tracing White, Auto White, Manual
AE (Auto Exposure Mode)	Auto, Flat, Spot, Center
Lens (wide to tele)	40x optical zoom ; f= 6.5 mm to 260mm, F1.4 to F4.9
Digital Zoom	16x
Angle of View	Horizontal : 57.0°(wide) ~ °1.98(tele) / Vertical : 33.4°(wide) ~ °0.89(tele) / Diagonal : 64.2°(wide) ~ °2.26(tele)
Minimum Focus Length	1 m to 10 m
Video	
Compression	H.265/H.264/MJPEG
Frame rate	Max 60fps @ 2304x1296
Bitrate	Primary : 32Kbps ~ 16Mbps, Secondary x3 : 32Kbps ~ 4Mbps
Resolution	352x240 ~ 2304x1296
Streaming	Primary : H.265/H.264, Secondary x 3 : H.265/H.264/MJPEG
Bitrate Control	CBR / VBR / Hybrid / Adaptive CBR / Smart CBR
Burn-in OSD	Multi-lingual
Audio	
Compression	G.711 / AAC
Sampling rate	G.711 : 8 KHz, AAC : 32 kHz / 44.1 kHz / 48 kHz
Bitrate	G.711 : 64Kbps, AAC: 64Kbps/128Kbps
Streaming	G.711 : Full-duplex, AAC : Full-duplex
Network	
Protocol	IPv4/v6, TCP, UDP, IGMP(Multicast), ICMP, DHCP, HTTP, HTTP, FTP, SNMP, SMTP, UPnP, WS-Discovery, Zero Configuration, NTP, SRT, MPEG-TS, RTP, RTSP, RTMP, DDNS
Security	Password protection, IP address filtering, HTTPS encryption, SRT
API	Truen protocol/SDK, ONVIF, PSIA
Interface	Ethernet 10/100/1000base-T / Connector : 1.25mm Conn - Connector : 1.25mm PITCH wire to board CONNECTOR (8pin of 12pin)
PTZ Control Protocol	40 types of control protocol including Pelco-D, Pelco-P, Visca
PTZ functionalities	Preset (500), Pattern (4), Swing (8), Group (8), Auto parking
General	
Power Supply	Min DC12V/2A
Power Consumption	DC12V: Max 13.6 W
Operating Temperature	-10°C ~ 50°C (14°F ~ 122°F)
Storage Temperature	-10°C ~ 50°C (14°F ~ 122°F)
Operating Humidity	20% ~ 80% RH
Storage Humidity	20% ~ 80% RH
Edge Storage	SD/SDHC/SDXC slot (Max 256GB) / Connector : Micro-Coaxial
Dimensions (W x H x D)	73.4mm X 78.2mm X 152.6mm
Weight	681.6g

Dimensions

< Front >

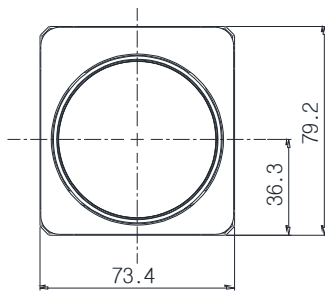

< Top >

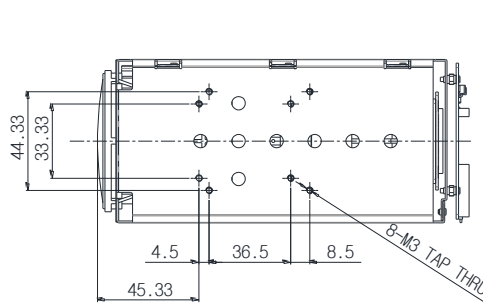

< Bottom >

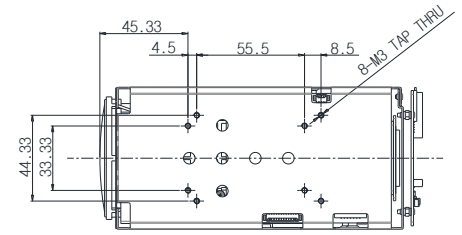

< Rear >

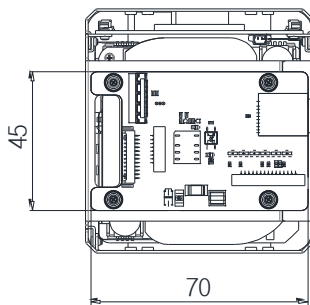

< Right side >

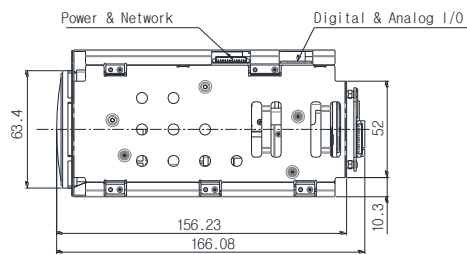

< Left side >

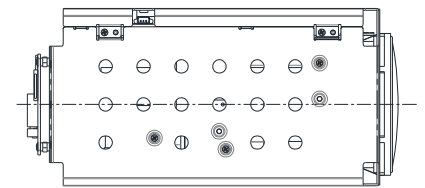

Pin Assignment & Connector

R31-J3				R31-J4			
Pin No.	Signal	Dir	Description	Pin No.	Signal	Dir	Description
1	EXT_RTX-	I/O	RS-485 -	1	NETWORK_A+	IO	Ethernet Positive Data 1
2	EXT_RTX+	I/O	RS-485 +	2	NETWORK_A-	IO	Ethernet Negative Data 1
3	IP_RESET	I	Factory reset Input(Active Low)	3	NETWORK_B+	IO	Ethernet Positive Data 2
4	Reserved	-	Reserved	4	NETWORK_B-	IO	Ethernet Negative Data 2
5	GND	PWR	Ground	5	NETWORK_C+	IO	Ethernet Positive Data 3
6	AC_OUT_L	O	Audio Line output	6	NETWORK_C-	IO	Ethernet Negative Data 3
7	GND	PWR	Ground	7	NETWORK_D+	IO	Ethernet Positive Data 4
8	AC_IN_L	I	Audio Line input	8	NETWORK_D-	IO	Ethernet Negative Data 4
9	GND	PWR	Ground				
10	ALARM_COM	O	Alarm signal				
11	ALARM_NO	O	Alarm signal				
12	SENSOR	I	Sensor signal				
13	GND	PWR	Ground				
14	DC12V	PWR	Supply Voltage				
15	DC12V	PWR	Supply Voltage				

TCB-2840F Specifications

Basic Specifications	
Image Sensor	1/1.8 Sony CMOS Sensor
Minimum Illumination	Color : 0.14 Lux at 1/15sec, 50IRE BW : 0 Lux at 1/15sec, 50IRE
Analog Gain / Digital Max Gain	1 to 30
Shutter Speed	1/1 to 1/100000
Maximum Aperture Ratio	F1.4 ~ F4.9
Defog	YES
Noise Reduction	2D, 3D
Gamma	0, 1, 2, Auto(Normal), Auto(Clear), Auto(Bright), Auto(Fine)
Wide Dynamic Range	Level 1 to Level 7
White Balance	Auto Tracing White, Auto White, Manual
AE (Auto Exposure Mode)	Auto, Flat, Spot, Center
Lens (wide to tele)	40x optical zoom ; f= 6.5mm to 260mm, F1.4 to F4.9
Digital Zoom	16x
Angle of View	Horizontal : 64.1°(wide) ~ °2.0(tele) / Vertical : 38.1°(wide) ~ °1.1(tele) / Diagonal : 71.5°(wide) ~ °2.3(tele)
Minimum Focus Length	1 m to 10 m
Video	
Compression	H.265/H.264/MJPEG
Frame rate	Max 60fps @ 3840x2160
Bitrate	Primary : 32Kbps ~ 16Mbps, Secondary x3 : 32Kbps ~ 4Mbps
Resolution	352x240 ~ 3840x2160
Streaming	Primary : H.265/H.264, Secondary x 3 : H.265/H.264/MJPEG
Bitrate Control	CBR / VBR / Hybrid / Adaptive CBR / Smart CBR
Burn-in OSD	Multi-lingual
Audio	
Compression	G.711 / AAC
Sampling rate	G.711 : 8 KHz, AAC : 32 kHz / 44.1 kHz / 48 kHz
Bitrate	G.711 : 64Kbps, AAC: 64Kbps/128Kbps
Streaming	G.711 : Full-duplex, AAC : Full-duplex
Network	
Protocol	IPv4/v6, TCP, UDP, IGMP(Multicast), ICMP, DHCP, HTTP, HTTP, FTP, SNMP, SMTP, UPnP, WS-Discovery, Zero Configuration, NTP, SRT, MPEG-TS, RTP, RTSP, RTMP, DDNS
Security	Password protection, IP address filtering, HTTPS encryption, SRT
API	Truen protocol/SDK, ONVIF, PSIA
Interface	Ethernet 10/100/1000base-T / Connector : 1.25mm Conn - Connector : 1.25mm PITCH wire to board CONNECTOR (8pin of 12pin)
PTZ Control Protocol	40 types of control protocol including Pelco-D, Pelco-P, Visca
PTZ functionalities	Preset (500), Pattern (4), Swing (8), Group (8), Auto parking
General	
Power Supply	Min DC12V/2A
Power Consumption	DC12V: Max 13.6 W
Operating Temperature	-10°C ~ 50°C (14°F ~ 122°F)
Storage Temperature	-10°C ~ 50°C (14°F ~ 122°F)
Operating Humidity	20% ~ 80% RH
Storage Humidity	20% ~ 80% RH
Edge Storage	SD/SDHC/SDXC slot (Max 256GB) / Connector : Micro-Coaxial
Dimensions (W x H x D)	73.4mm X 78.2mm X 152.6mm
Weight	681.6g

Dimensions

< Front >

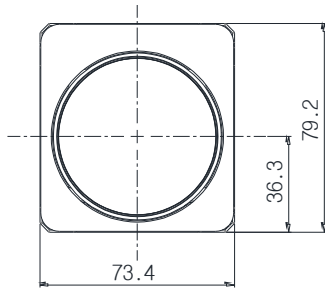

< Top >

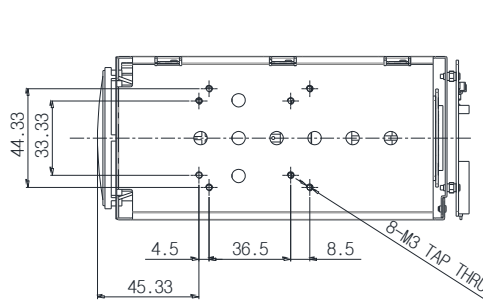

< Bottom >

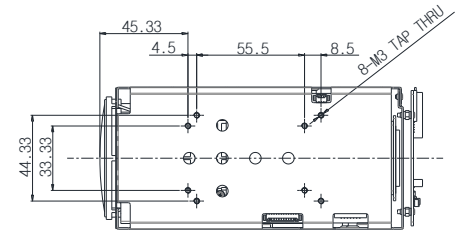

< Rear >

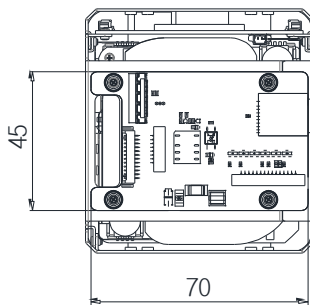

< Right side >

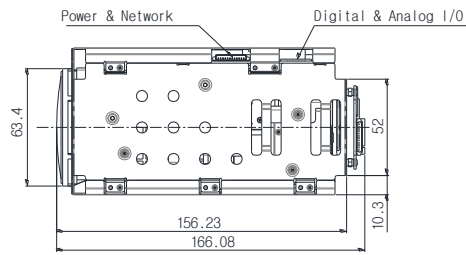

< Left side >

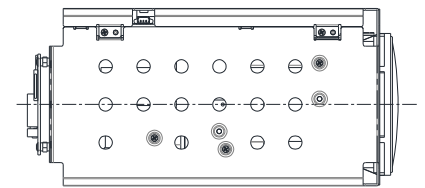

Pin Assignment & Connector

R31-J3				R31-J4			
Pin No.	Signal	Dir	Description	Pin No.	Signal	Dir	Description
1	EXT_RTX-	I/O	RS-485 -	1	NETWORK_A+	IO	Ethernet Positive Data 1
2	EXT_RTX+	I/O	RS-485 +	2	NETWORK_A-	IO	Ethernet Negative Data 1
3	IP_RESET	I	Factory reset Input(Active Low)	3	NETWORK_B+	IO	Ethernet Positive Data 2
4	Reserved	-	Reserved	4	NETWORK_B-	IO	Ethernet Negative Data 2
5	GND	PWR	Ground	5	NETWORK_C+	IO	Ethernet Positive Data 3
6	AC_OUT_L	O	Audio Line output	6	NETWORK_C-	IO	Ethernet Negative Data 3
7	GND	PWR	Ground	7	NETWORK_D+	IO	Ethernet Positive Data 4
8	AC_IN_L	I	Audio Line input	8	NETWORK_D-	IO	Ethernet Negative Data 4
9	GND	PWR	Ground				
10	ALARM_COM	O	Alarm signal				
11	ALARM_NO	O	Alarm signal				
12	SENSOR	I	Sensor signal				
13	GND	PWR	Ground				
14	DC12V	PWR	Supply Voltage				
15	DC12V	PWR	Supply Voltage				

TCB-2844F Specifications

Basic Specifications	
Image Sensor	1/1.8 Sony CMOS Sensor
Minimum Illumination	Color : 0.14 Lux at 1/15sec, 50IRE BW : 0 Lux at 1/15sec, 50IRE
Analog Gain / Digital Max Gain	1 to 30
Shutter Speed	1/1 to 1/100000
Maximum Aperture Ratio	F1.4 ~ F4.9
Defog	YES
Noise Reduction	2D, 3D
Gamma	0, 1, 2, Auto(Normal), Auto(Clear), Auto(Bright), Auto(Fine)
Wide Dynamic Range	Level 1 to Level 7
White Balance	Auto Tracing White, Auto White, Manual
AE (Auto Exposure Mode)	Auto, Flat, Spot, Center
Lens (wide to tele)	40x optical zoom ; f= 6.5mm to 260mm, F1.4 to F4.9
Digital Zoom	16x
Angle of View	Horizontal : 65.2°(wide) ~ °1.7(tele) / Vertical : 38.4°(wide) ~ °1.0(tele) / Diagonal : 73.3°(wide) ~ °1.9(tele)
Minimum Focus Length	1 m to 10 m
Video	
Compression	H.265/H.264/MJPEG
Frame rate	Max 60fps @ 3840x2160
Bitrate	Primary : 32Kbps ~ 16Mbps, Secondary x3 : 32Kbps ~ 4Mbps
Resolution	352x240 ~ 3840x2160
Streaming	Primary : H.265/H.264, Secondary x 3 : H.265/H.264/MJPEG
Bitrate Control	CBR / VBR / Hybrid / Adaptive CBR / Smart CBR
Burn-in OSD	Multi-lingual
Audio	
Compression	G.711 / AAC
Sampling rate	G.711 : 8 KHz, AAC : 32 kHz / 44.1 kHz / 48 kHz
Bitrate	G.711 : 64Kbps, AAC: 64Kbps/128Kbps
Streaming	G.711 : Full-duplex, AAC : Full-duplex
Network	
Protocol	IPv4/v6, TCP, UDP, IGMP(Multicast), ICMP, DHCP, HTTP, HTTP, FTP, SNMP, SMTP, UPnP, WS-Discovery, Zero Configuration, NTP, SRT, MPEG-TS, RTP, RTSP, RTMP, DDNS
Security	Password protection, IP address filtering, HTTPS encryption, SRT
API	Truen protocol/SDK, ONVIF, PSIA
Interface	Ethernet 10/100/1000base-T / Connector : 1.25mm Conn - Connector : 1.25mm PITCH wire to board CONNECTOR (8pin of 12pin)
PTZ Control Protocol	40 types of control protocol including Pelco-D, Pelco-P, Visca
PTZ functionalities	Preset (500), Pattern (4), Swing (8), Group (8), Auto parking
General	
Power Supply	Min DC12V/2A
Power Consumption	DC12V: Max 13.6 W
Operating Temperature	-10°C ~ 50°C (14°F ~ 122°F)
Storage Temperature	-10°C ~ 50°C (14°F ~ 122°F)
Operating Humidity	20% ~ 80% RH
Storage Humidity	20% ~ 80% RH
Edge Storage	SD/SDHC/SDXC slot (Max 256GB) / Connector : Micro-Coaxial
Dimensions (W x H x D)	73.4mm X 78.2mm X 152.6mm
Weight	681.6g

Dimensions

< Front >

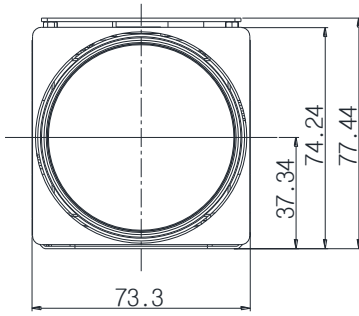

< Top >

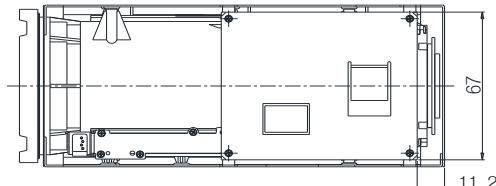

< Bottom >

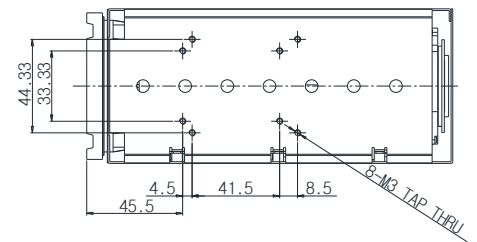

< Rear >

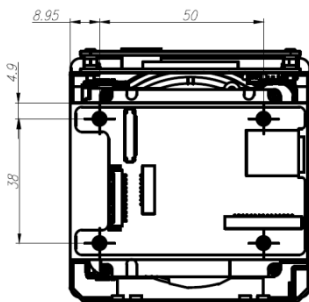

< Right side >

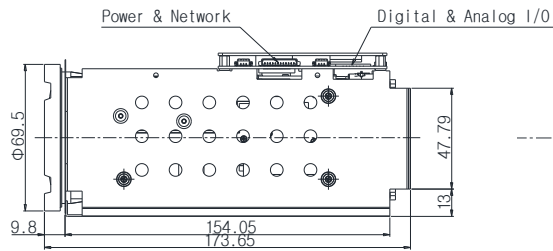

< Left side >

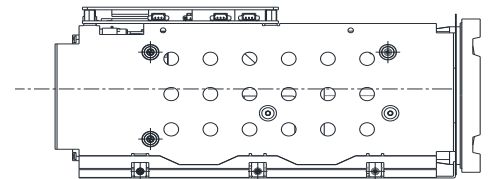

Pin Assignment & Connector

R31-J3				R31-J4			
Pin No.	Signal	Dir	Description	Pin No.	Signal	Dir	Description
1	EXT_RTX-	I/O	RS-485 -	1	NETWORK_A+	IO	Ethernet Positive Data 1
2	EXT_RTX+	I/O	RS-485 +	2	NETWORK_A-	IO	Ethernet Negative Data 1
3	IP_RESET	I	Factory reset Input(Active Low)	3	NETWORK_B+	IO	Ethernet Positive Data 2
4	Reserved	-	Reserved	4	NETWORK_B-	IO	Ethernet Negative Data 2
5	GND	PWR	Ground	5	NETWORK_C+	IO	Ethernet Positive Data 3
6	AC_OUT_L	O	Audio Line output	6	NETWORK_C-	IO	Ethernet Negative Data 3
7	GND	PWR	Ground	7	NETWORK_D+	IO	Ethernet Positive Data 4
8	AC_IN_L	I	Audio Line input	8	NETWORK_D-	IO	Ethernet Negative Data 4
9	GND	PWR	Ground				
10	ALARM_COM	O	Alarm signal				
11	ALARM_NO	O	Alarm signal				
12	SENSOR	I	Sensor signal				
13	GND	PWR	Ground				
14	DC12V	PWR	Supply Voltage				
15	DC12V	PWR	Supply Voltage				